

RAL 9006 - minimalna grubość warstwy lakieru 50 µm  
Wykończenie powierzchni: lakierowana blacha

NUMER SERYJNY BRAMY		<b>SGS-2T / EI-C 60 DP1</b>						
NUMER RYSUNKU	SZTUK	WAGA [kg]	MATERIAŁ PÓLFABRYKAT	SKALA	DATA	OPRACOWAL	KLASA PRECYZJI	RZUTOWANIE [ISO E]
	1	1560	---	1:60 1:8	4.3.2014	GTK	ISO 2768-mL	
PROJEKT							<b>somati system</b> 45-231 Opole, ul. Oleska 125 tel. 77 453 16 02	
NAZWA RYSUNKU	<b>SGS-2T 6,75 x 3,40 m prawe</b>							

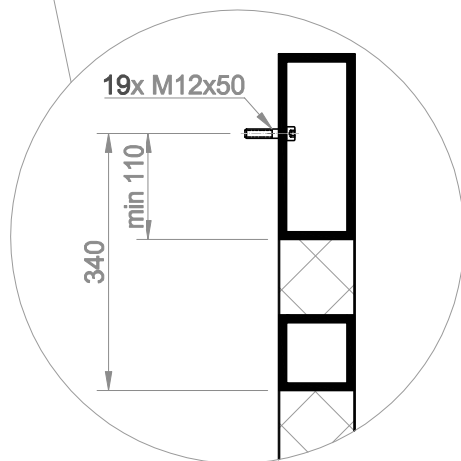
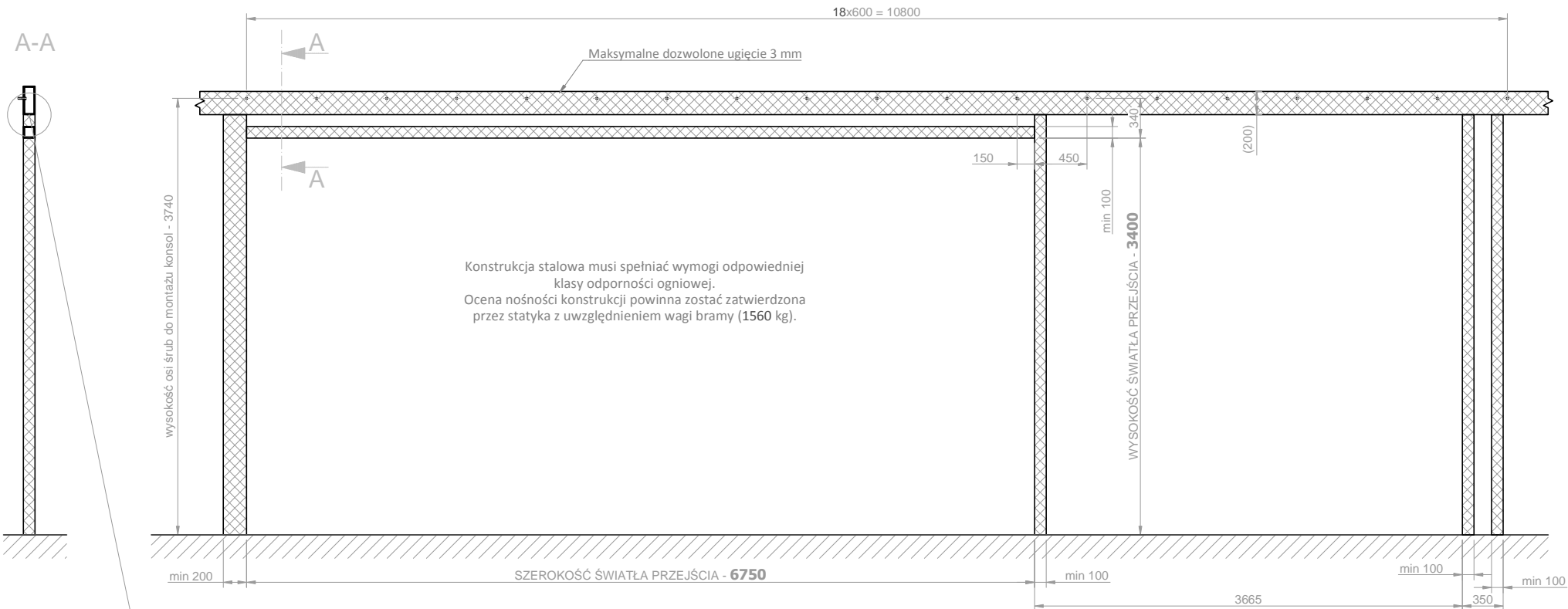

NUMER SERYJNY BRAMY		<b>SGS-2T / EI-C 60 DP1</b>						
NUMER RYSUNKU	SZTUK	WAGA [kg]	MATERIAŁ PÓLFABRYKAT	SKALA	DATA	OPRACOWAL	KLASA PRECYZJI	RZUTOWANIE [ISO E]
	1	---	---	1:50 1:10	4.3.2014	GTK	ISO 2768-mL	
PROJEKT							<b>somati system</b> 45-231 Opole, ul. Oleska 125 tel. 77 453 16 02	
NAZWA RYSUNKU	<b>Konstrukcja stalowa</b>							