

RAL 9002 - minimalna grubość warstwy lakieru 25 µm
 Wykończenie powierzchni: lakierowana blacha

NUMER SERYJNY BRAMY		SGS / EI-C 120 DP1						
NUMER RYSUNKU	SZTUK	WAGA [kg]	MATERIAŁ PÓŁFABRYKAT	SKALA	DATA	OPRACOWAŁ	KLASA PRECYZJI	RZUTOWANIE [ISO E]
	1	400	---	1:40 1:8	6.5.2014	ESA	ISO 2768-mL	
PROJEKT								
NAZWA RYSUNKU	SGS 1,90 x 2,10 m prawa						45-231 Opole, ul. Olęska 125 tel. 77 453 16 02	

A-A

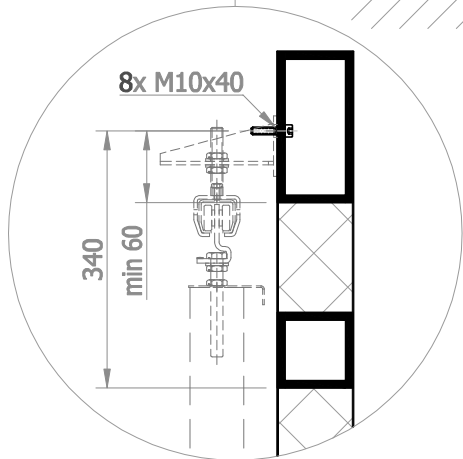
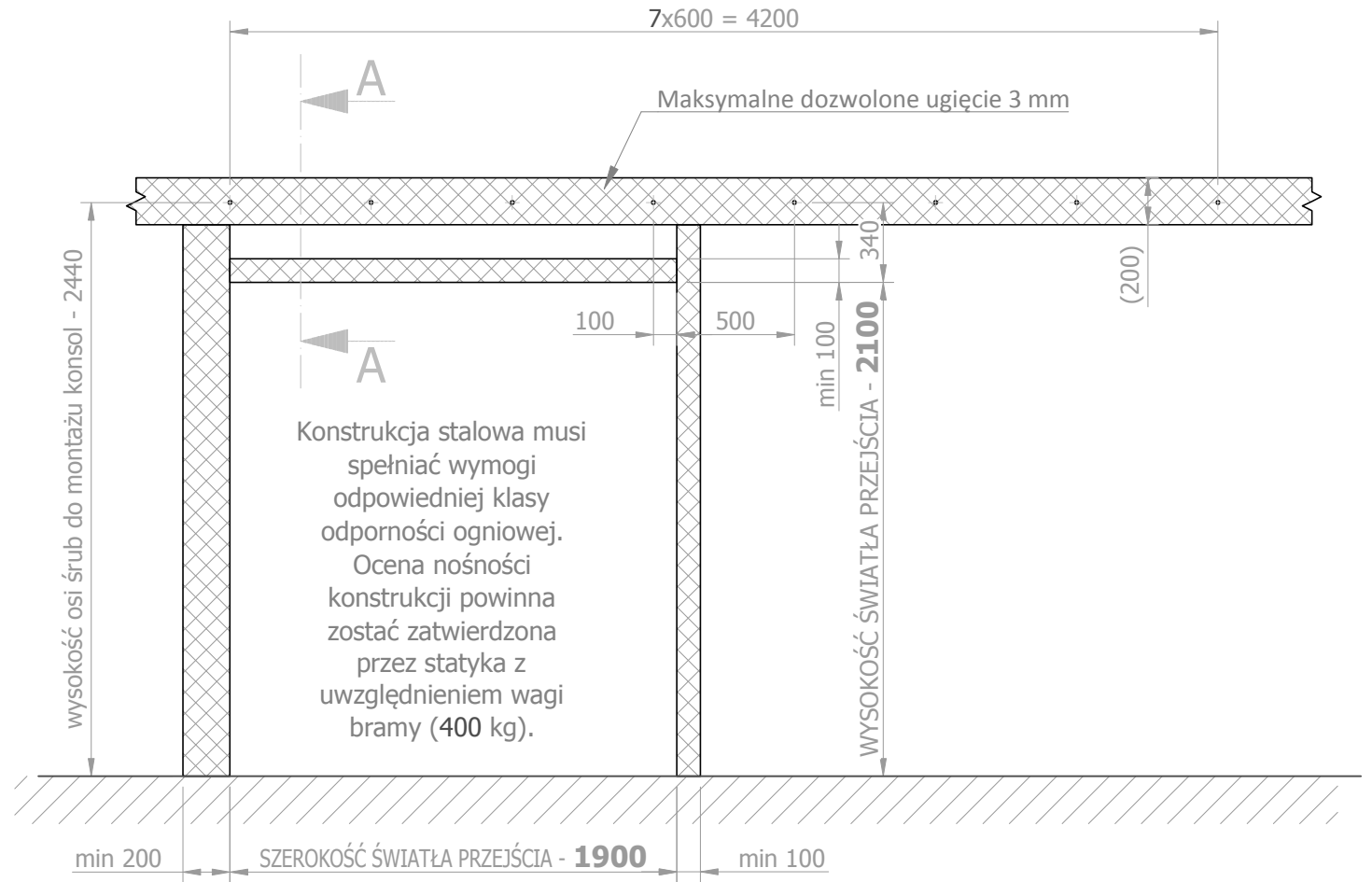

NUMER SERYJNY BRAMY		SGS / EI-C 120 DP1						
NUMER RYSUNKU	SZTUK	WAGA [kg]	MATERIAŁ PÓLFABRYKAT	SKALA	DATA	OPRACOWAL	KLASA PRECYZJI	RZUTOWANIE [ISO E]
	---	---	---	1:30 1:10	6.5.2014	ESA	ISO 2768-mL	
PROJEKT							 45-231 Opole, ul. Oleska 125 tel. 77 453 16 02	
NAZWA RYSUNKU	Konstrukcja stalowa							