

Wykończenie powierzchni: OCYNK

NUMER SERYJNY BRAMY		<b>RGS-60-H / EI-C 60 DP1</b>						
NUMER RYSUNKU	SZTUK	WAGA [kg]	MATERIAŁ PÓLFABRYKAT	SKALA	DATA	OPRACOWAL	KLASA PRECYZJI	RZUTOWANIE [ISO E]
	1	1550	---	1:45 1:8	21.7.2015	ESA	ISO 2768-mL	
PROJEKT							<b>somati system</b> 45-231 Opole, ul. Oleska 125 tel. 77 453 16 02	
NAZWA RYSUNKU	<b>RGS-H 5,60 x 2,20 m</b>							

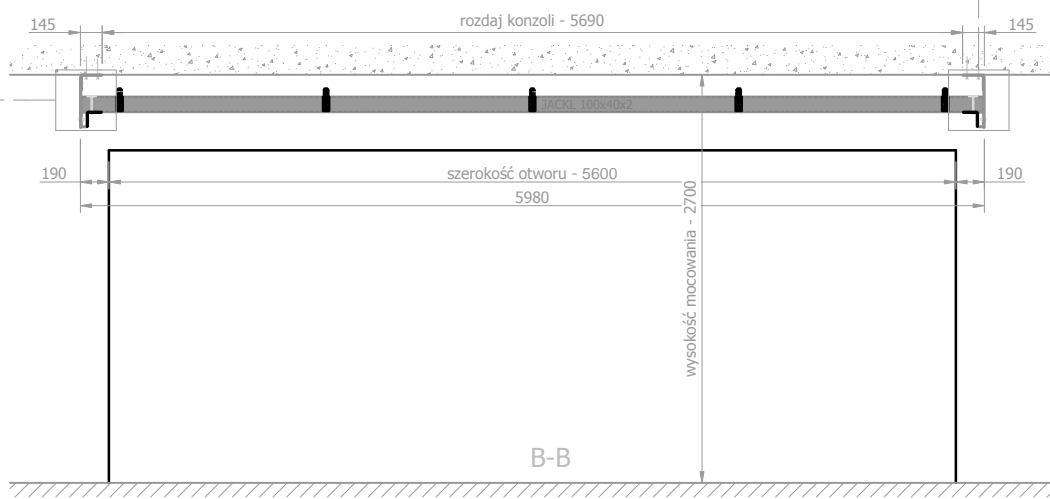
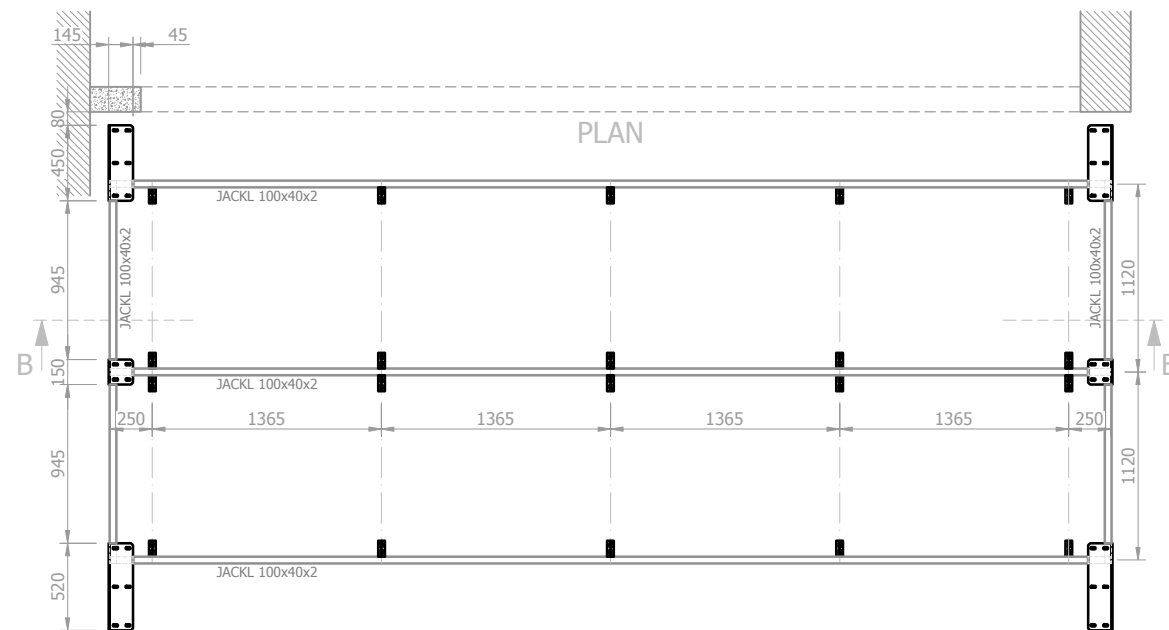
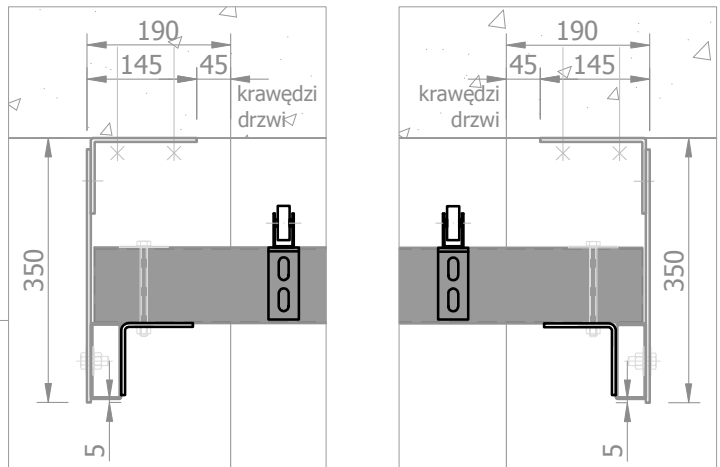

NUMER SERYJNY BRAMY		<b>RGS-60-H / EI-C 60 DP1</b>						
NUMER RYSUNKU	SZTUK	WAGA [kg]	MATERIAL PÓLFABRYKAT	SKALA	DATA	OPRACOWAL	KLASA PRECYZJI	RZUTOWANIE [ISO E]
	1	---	jackl 100x40x2	1:50, 1:45 1:10	21.7.2015	ESA	ISO 2768-mL	
PROJEKT							<b>somati system</b> 45-231 Opole, ul. Oleska 125 tel. 77 453 16 02	
NAZWA RYSUNKU	<b>Konstrukcja stalowa</b>							